

QuantumBins.com shop & order on-line or call Toll Free (866) 654-4808

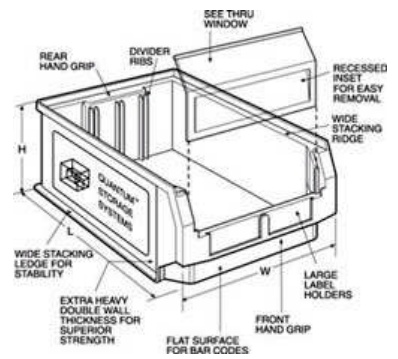

Toughest bins MAGNUM Bins in the business!



Magnum Bins – The Toughest Bins in the Business!

Heavy duty, extra strong injection molded, high-density polyethylene bins are ideal for transportation and storage of large and heavy parts. Open hopper front allows immediate access and visibility. Ribbed reinforced walls ensure ultimate strength. Double wall thickness with preformed lip allows bin to interlock and provides up to 150 lbs. stack capacity. Transport these bins easily with rear-molded handle. Impervious to most solvents, corrosion, rust and rot resistant. Resists temperatures from -40°F to 250°F. Optional window maximizes storage and prevents spillage. Colors available here on-line are **Blue, Yellow, Green, Red and Black**.

Magnum bins are available in all colors on-line at **QuantumBins.com** or call **(866) 654-4808**

MODEL NO.	OUTSIDE DIMENSIONS L" x W" x H"	INSIDE DIMENSIONS L" x W" x H"	CTN QTY	CTN WGT	CTN DIVIDERS	CTN QTY	CTN WINDOWS	CTN QTY
QMS 531	19-3/4" x 12-3/8" x 5-7/8"	17-3/4" x 11-1/4" x 5-1/8"	6	19 lbs	DMS 531	6	WMS 531	6
QMS 532	19-3/4" x 12-3/8" x 7-7/8"	17-3/4" x 11-1/4" x 7-1/4"	6	23 lbs	DMS 532	6	WMS 532	6
QMS 533	19-3/4" x 12-3/8" x 11-7/8"	17-3/4" x 11-1/4" x 11"	3	15 lbs	DMS 533	3	WMS 533	3
QMS 543	19-3/4" x 18-3/8" x 11-7/8"	17-3/4" x 17-1/4" x 11"	1	8 lbs	DMS 543	1	WMS 543	1
QMS 743*	29" x 18-3/8" x 11-7/8"	26-3/4" x 17-1/4" x 11"	1	10 lbs				
QMS 843MOB*	29" x 18-3/8" x 14-7/8"	26-3/4" x 17-1/4" x 11"	1	14 lbs				

*Includes heavy duty spread bar for extra strength and support.



QuantumBins.com is one of the **MainStreetE.com** owned & operated family of on-line stores.